



Description

For reliable, simple and automatic removal of solids from wastewater.

The screw screen separates solids from the waste water. In the first stage, the solids floating in the water are separated by an upstream screen. After reaching a certain level, the screw conveyor cleans the screen basket with the brushes mounted on the screw spirals. The separated material is conveyed upwards, compacted and dewatered. The system is designed in such a way that clogging is not possible.

The machine consists of the following parts

- Inlet flange
- Overflow
- Outlet flange
- Optional automatic washing
- Screw
- Screen [0.25mm-10mm]
- Screw motor
- Remote monitoring

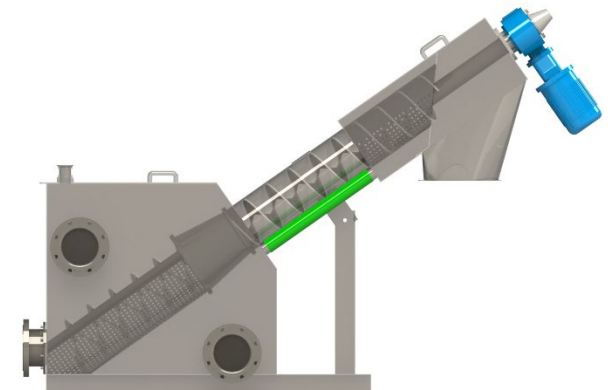

Technical data, part 1

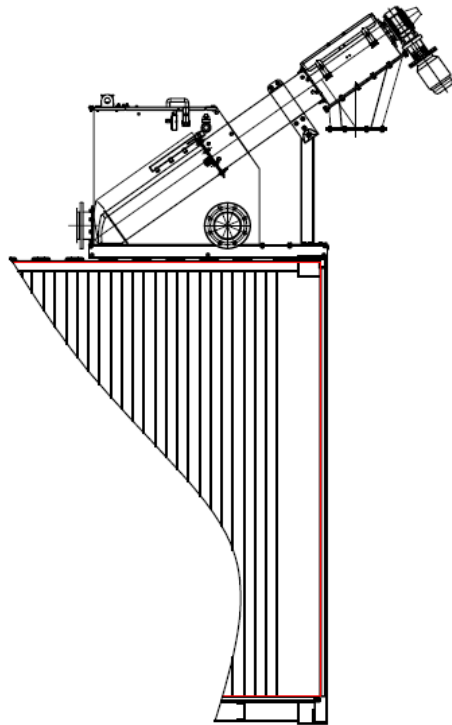

Module	CSS 90	CSS 160	CSS 250	CSS 300
Max. Flow rate *1	94 m³/hr (26 l/s)	155 m³/hr (43 l/s)	248 m³/hr (69 l/s)	303 m³/hr (84 l/s)
Measurements (L/B/H)	2595x480x1795 mm	2980x430x2110 mm	2980x480x2100 mm	2978x480x2021 mm
Material (except flanges)	Stainless steel 304L or 316L / High-grade steel 304L or 316L			
Lateral position inlet/outlet	Right or left (depending on requirement)			
Shaft without screw	High carbon steel (special steel S355JR)			
Net weight	300 kg	350 kg	350 kg	400 kg
Screw press:				
Max. Solids concentration	Max. 50% (max. 500 mg/l)			
Material flange inlet, outlet (and optional emergency overflow) *2	Aluminum			
	DNI50 PN10	DNI50 PN10	DN200 PN10	DN250 PN10
Filter diameter round hole *3	3 mm	5 mm	5 mm	3 mm
Diameter of the sieve basket	200 mm	200 mm	270 mm	300 mm
Inlet height (pipe centre)	200 mm	220 mm	250 mm	230 mm
Outlet height (centre of pipe)	1015 mm	1500 mm	1500 mm	1240 mm
Screw shaft inserts	1	1	2	2
Diameter / Pitch / Thickness screw shaft	195 mm / 145 mm / 15 mm			
Current (ATEX protection optional)	1,1 kW	0,75 kW	0,75 kW	1,1 kW
Voltage	380-420 V / 50Hz - 440-480 V / 60 Hz; IP 55 F class			

*1: The flow rate depends on the screen width. If the solids content is higher, the flow rate can be reduced.

*2: Depending on the requirements, the size of the flanges can be adjusted.

*3: Type of sieve basket (wedge wire or round hole) and sieve mesh width can be adjusted according to requirements.

Technical data, part 2



Module	CSS 380	CSS 610	CSS 960
Max. Flow rate *1	378 m³/hr (105 l/s)	612 m³/hr (170 l/s)	963 m³/hr (268 l/s)
Measurements (L/B/H)	3010x600x2100 mm	2980x650x2150 mm	3460x720x2500 mm
Material (except flanges)	Stainless steel 304L or 316L / High-grade steel 304L or 316L		
Lateral position inlet/outlet	Right or left (depending on requirement)		
Shaft without screw	High carbon steel (special steel S355JR)		
Net weight	450 kg	500 kg	650 kg
Screw press:			
Max. Solids concentration	Max. 50% (max. 500 mg/l)		
Material flange inlet, outlet (and optional emergency overflow) *2	Aluminum		
	DN250 PN10	DN300 PN10	DN 400 PN 10
Filter diameter round hole *3	3 mm	3 mm	3 mm
Diameter of the sieve basket	350 mm	450 mm	615 mm
Inlet height (pipe centre)	285 mm	315 mm	380 mm
Outlet height (centre of pipe)	1500 mm	1500 mm	1750 mm
Screw shaft inserts	2	2	2
Diameter / Pitch / Thickness screw shaft	195 mm / 145 mm / 15 mm		
Current (ATEX protection optional)	1,1 kW	0,75 kW	0,75 kW
Voltage	380-420 V / 50Hz - 440-480 V / 60 Hz; IP 55 F class		

*1: The flow rate depends on the screen width. If the solids content is higher, the flow rate can be reduced.

*2: Depending on the requirements, the size of the flanges can be adjusted.

*3: Type of sieve basket (wedge wire or round hole) and sieve mesh width can be adjusted according to requirements.

Application

For all types of domestic, municipal and industrial wastewater. In each case, the design must be individually adapted to the purpose.

Features of the ClearFox® compact screw screens

- Volume reduction of solids by up to 50%
- Low speed motor
- Heavy duty screw
- Screening, conveying, and compacting in a single unit with only one motor
- Easy installation
- Low maintenance
- Durable attachable screw brushes that are self-cleaning
- Low operating costs
- No clogging even with fibers due to the shaftless screw design
- Outdoor installation with optional frost protection accessories

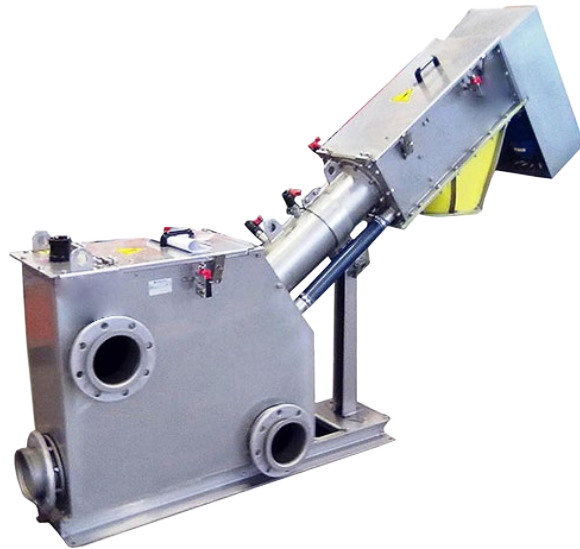



Options on request

- Endless hose for guided coarse material discharge
- Emergency overflow
- The inlet area of the tank can be equipped with a screen grate in bypass function
- Sieve mesh width: 0.25/0.5/1/2/3 mm (wedge wire) 2/3/4/5/6/7/10 mm (round hole)
- Washing system for the transport area
- Insulation for transport section / compressor
- ATEX motors
- GSM network connection (transmission to mobile networks)
- Housing for control cabinet

Advantages of ClearFox® compact screw screens:

- Fast commissioning, cost saving during installation, low space requirement
- Modular system, adaptable to any application
- High performance with high quality, Made in Germany
- Flexible against underload and overload
- Industrial and municipal wastewater
- stable and very robust process technology