

Basics:

Prechamber desludging interval ~ 3 months

Effluent class N

Specific waste water load = 150 liters / d x p.e.

Specific organic load = 60 gr / d x p.e.

required connection pipe
KG DN 150 from client for
hose and cable connection
(cable and hoses max. 10 m)

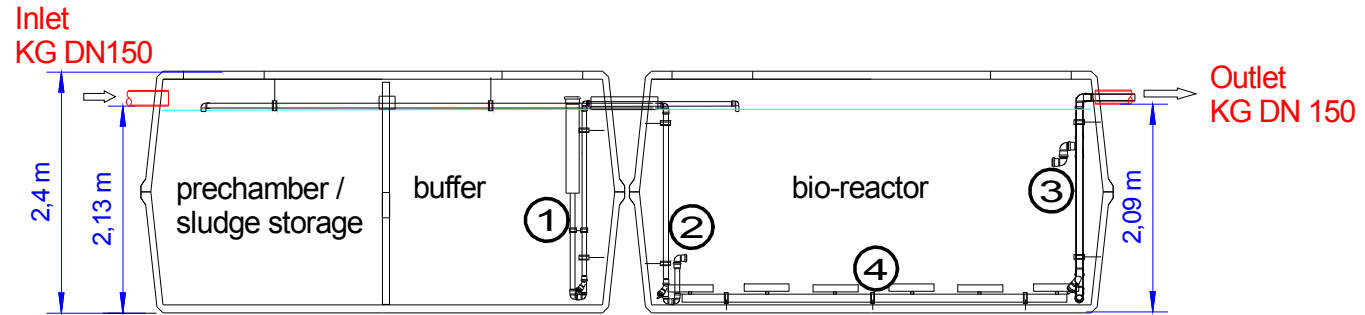
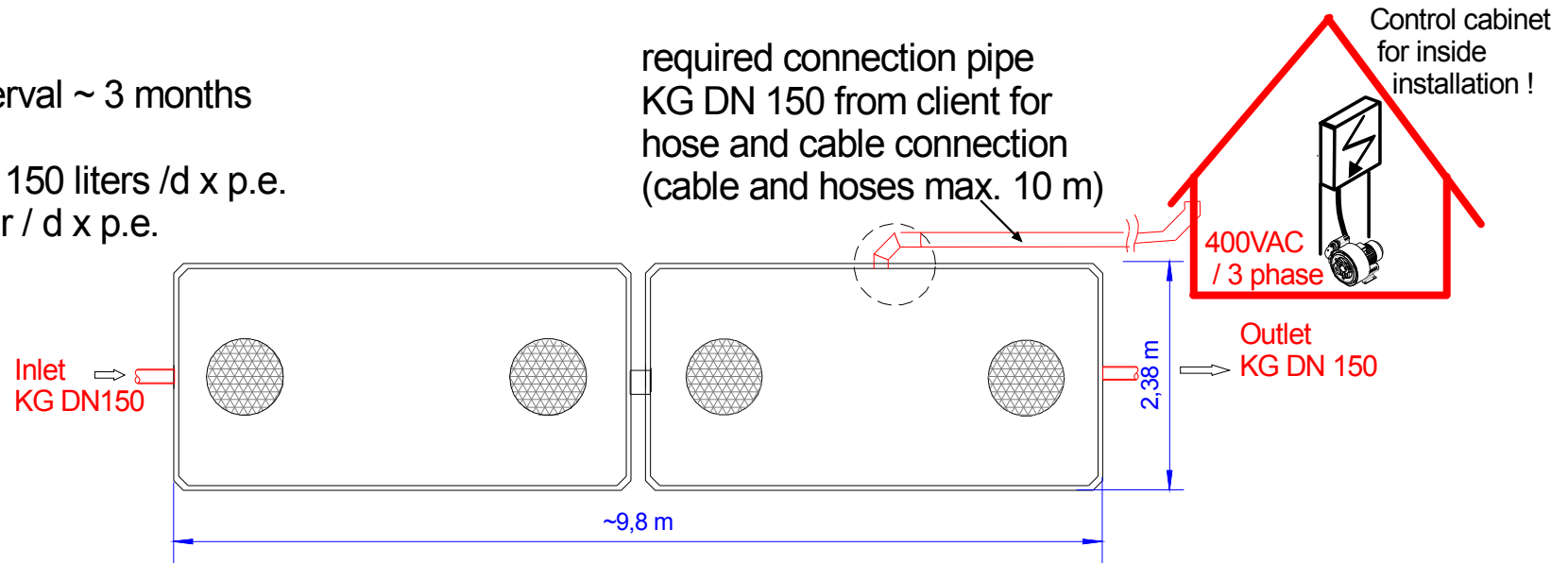

- By client
- ClearFox

1. Airlift pump filling
2. Airlift pump secondary sludge
3. Airlift pump clearwater
4. Aeration system

tank	tara weight in kg
tank 1	9050
tank 2	9150
equipment	225
complete	18425

Subject to technical changes

air hose	power input ~[kW]
1" (50 m)	1,5

CF - SBR wwtp 26m³/d

plug and play system for underground installation