

**Basics:**

Prechamber desludging interval ~ 12 months

Effluent class N

Specific waste water load = 150 liters / d x p.e.

Specific organic load = 60 gr / d x p.e.

required connection pipe  
KG DN 150 from client for  
hose and cable connection  
(cable and hoses max. 10 m)

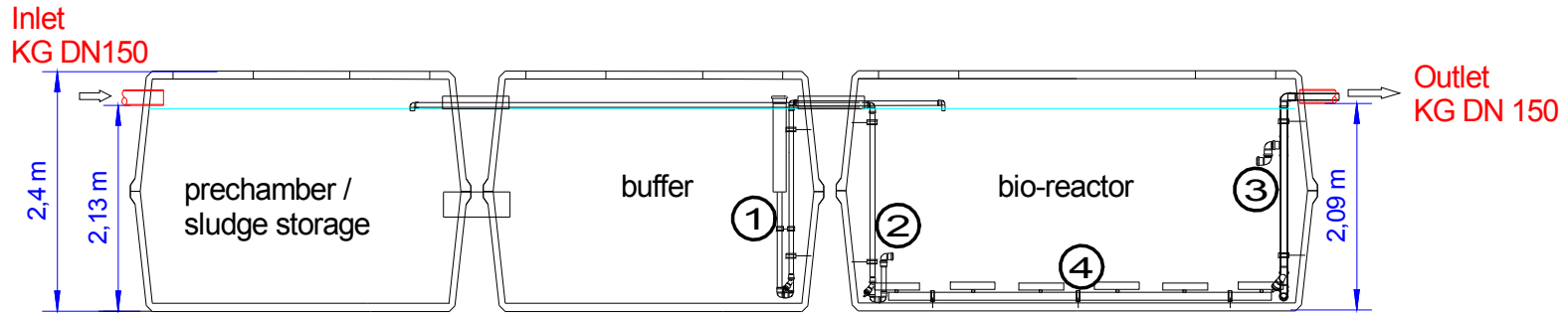
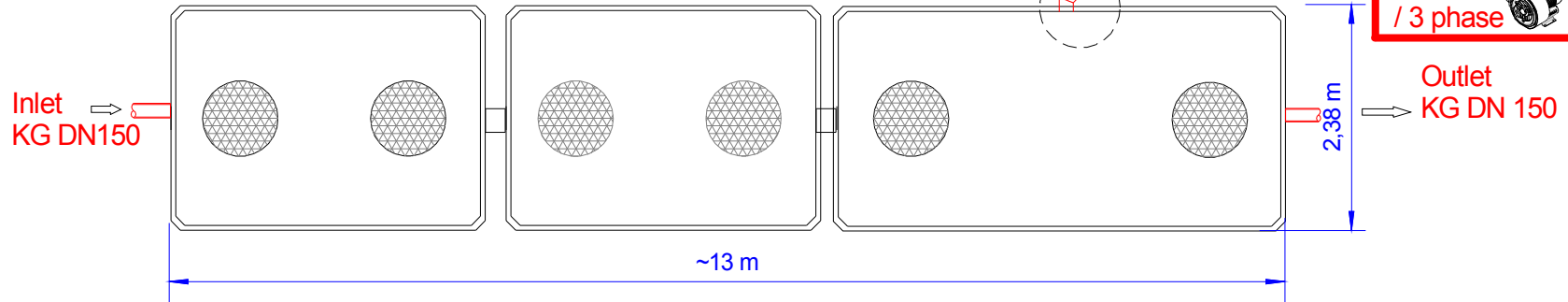
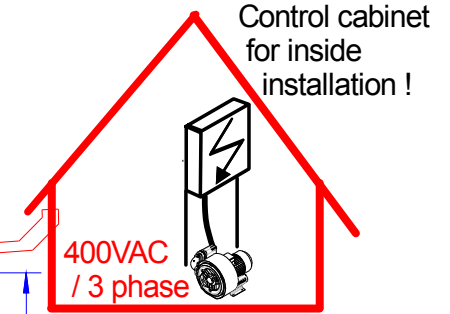

- By client
- ClearFox

1. Airlift pump filling
2. Airlift pump secondary sludge
3. Airlift pump clearwater
4. Aeration system

tank	tara weight in kg
tank 1	7500
tank 2	7505
tank 3	9150
complete	24155

Subject to technical changes

air hose	power input ~[kW]
1" (50 m)	1,2

CF - SBR wwtp 100 p.e.

plug and play system for underground installation

Copyright at PPU

www.clearfox.com



Please note: All our drawing are in property. All rights reserved. Duplication only with prior approval of PPU.

Datum: 12.02.2016

DIN A4

M /

gez.: mz